

STATE OF ARIZONA }
 COUNTY OF PINAL } SS

I HEREBY CERTIFY THAT THE WITHIN INSTRUMENT IS FILED IN THE OFFICIAL RECORDS OF THIS COUNTY IN CABINET _____ SLIDE _____

DATE: _____
 REQUEST OF: _____
 WITNESS MY HAND AND OFFICIAL SEAL.
 LAURA DEAN-LYTTLE, PINAL COUNTY RECORDER
 BY: _____ DEPUTY

COUNTY SEAL

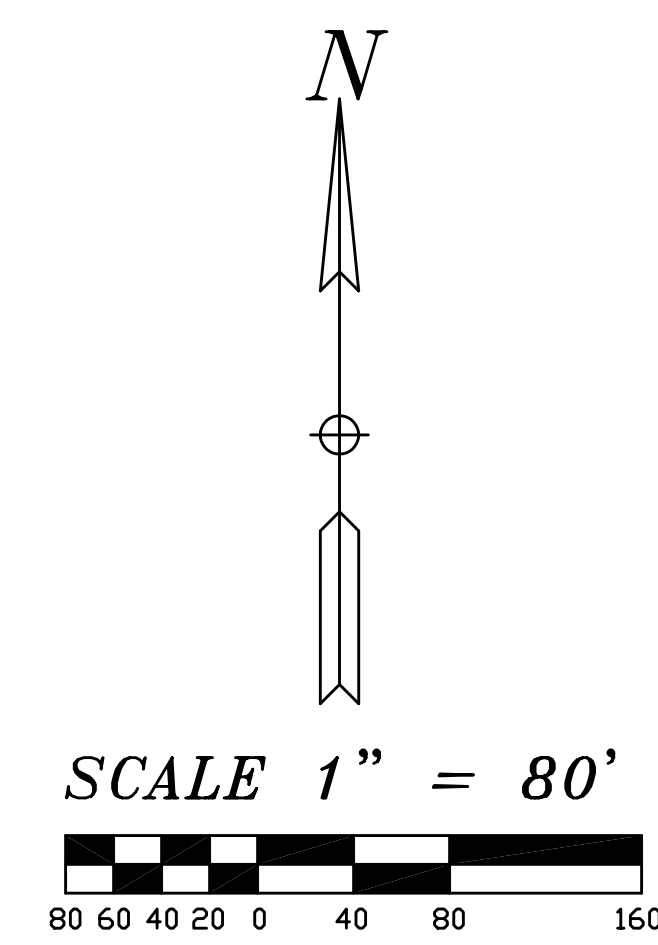

LINE TABLE FOR CENTERLINE OF DRAINAGE EASEMENT

NUMBER	DIRECTION	DISTANCE
DE1	N 39°27'34" E	61.53'
DE2	N 51°23'55" E	68.54'
DE3	N 51°23'55" E	43.42'
DE4	N 33°30'34" E	121.15'
DE5	N 04°21'04" E	125.01'
DE6	N 08°52'10" E	102.36'
DE7	N 32°55'46" W	31.26'
DE8	N 32°55'46" W	166.30'
DE9	N 10°05'09" W	137.66'
DE10	N 10°05'09" W	34.70'
DE11	N 10°05'09" W	33.20'
DE12	N 25°29'37" E	30.26'
DE13	N 25°29'37" E	107.09'
DE14	N 11°33'58" E	69.38'
DE15	N 08°20'31" W	175.94'
DE16	N 10°14'03" E	60.29'
DE17	N 10°14'03" E	58.44'
DE18	N 01°26'20" W	79.95'
DE19	N 01°39'26" W	127.53'
DE20	N 01°34'23" W	125.04'
DE21	N 10°52'43" W	129.64'
DE22	N 17°54'21" W	115.99'
DE23	N 32°08'20" W	34.60'
DE24	N 32°08'20" W	41.61'
DE25	N 43°10'04" W	98.76'
DE26	N 31°28'41" W	51.34'
DE27	N 31°28'41" W	70.23'
DE28	N 78°01'49" W	18.15'
DE29	N 55°46'37" W	69.81'
DE30	N 45°35'39" W	50.32'
DE31	N 39°19'14" W	50.82'
DE32	N 26°14'39" W	61.65'
DE33	N 20°59'04" W	69.72'
DE34	N 20°59'04" W	33.50'
DE35	N 35°33'08" W	48.26'
DE36	N 59°18'39" W	58.49'
DE37	N 62°57'18" W	90.40'
DE38	N 40°28'34" W	56.14'
DE39	N 19°08'36" E	82.29'
DE40	N 03°38'06" E	12.32'
DE41	N 03°38'06" E	37.76'
DE42	N 24°01'54" E	79.90'
DE43	N 35°04'39" E	45.97'
DE44	N 35°04'39" E	13.56'
DE45	N 28°08'36" E	46.83'
DE46	N 12°12'25" E	30.03'
DE47	N 43°27'39" E	133.37'

CURVE TABLE

Curve Number	Delta	Radius	Arc Length	Tangent Length	Chord Bearing	Chord Length
C1	3°32'34"	400.00'	24.73'	12.37'	N 02°13'16"W	24.73'
C2	10°45'16"	400.00'	75.08'	37.65'	N 09°22'11"W	74.97'
C3	11°39'34"	400.00'	81.40'	40.84'	N 08°55'02"W	81.26'
C4	28°13'34"	200.00'	98.53'	50.28'	N 11°01'32"E	97.53'
C5	21°46'41"	200.00'	76.02'	38.47'	N 36°01'39"E	75.56'
C6	5°34'03"	200.00'	19.43'	9.72'	N 44°07'58"E	19.43'
C7	33°28'38"	200.00'	116.86'	60.15'	N 65°23'22"W	115.20'
C8	44°26'12"	200.00'	155.11'	81.69'	N 19°07'51"E	151.25'
C9	47°28'52"	200.00'	165.74'	87.96'	N 72°23'29"W	161.04'
C10	5°58'24"	400.00'	41.70'	20.87'	N 11°45'37"W	41.68'
C11	8°19'26"	400.00'	58.11'	29.11'	N 04°36'42"W	58.06'
C12	31°38'52"	200.00'	110.47'	56.68'	N 15°41'11"E	109.07'
C13	40°44'49"	400.00'	284.47'	148.55'	N 11°08'13"E	278.51'
C14	19°03'31"	400.00'	133.05'	67.15'	N 18°45'57"W	132.44'
C15	11°04'54"	200.00'	38.68'	19.40'	N 22°45'16"W	38.62'
C16	11°04'54"	200.00'	38.68'	19.40'	N 11°40'22"W	38.62'
C17	14°00'14"	200.00'	48.88'	24.56'	N 89°07'48"W	48.76'
C18	22°09'48"	200.00'	77.36'	39.17'	N 17°12'49"W	76.88'
C19	11°16'54"	400.00'	8.95'	4.47'	N 27°39'16"W	8.95'
C20	21°17'36"	400.00'	148.66'	75.20'	N 16°22'01"W	147.80'
C21	19°09'01"	400.00'	133.69'	67.48'	N 03°51'17"E	133.07'
C22	18°04'49"	400.00'	126.22'	63.64'	N 22°28'13"E	125.70'

LOT TABLE

LOT #	AREA S.F.	AREA AC.
1	58,131 S.F.	1,334.5 AC.
2	58,346 S.F.	1,339.4 AC.
3	59,039 S.F.	1,355.3 AC.
4	57,778 S.F.	1,326.4 AC.
5	58,020 S.F.	1,332.0 AC.
6	59,257 S.F.	1,360.4 AC.
7	60,341 S.F.	1,382.2 AC.
8	56,413 S.F.	1,295.0 AC.
9	60,261 S.F.	1,383.4 AC.
10	60,330 S.F.	1,385.0 AC.
11	67,021 S.F.	1,538.6 AC.
12	61,138 S.F.	1,403.5 AC.
13	59,870 S.F.	1,374.4 AC.
14	59,443 S.F.	1,364.6 AC.
15	63,469 S.F.	1,457.0 AC.
16	58,485 S.F.	1,342.6 AC.
17	64,558 S.F.	1,525.2 AC.
18	74,917 S.F.	1,719.8 AC.
19	59,436 S.F.	1,364.4 AC.
20	58,942 S.F.	1,353.1 AC.
21	58,994 S.F.	1,354.3 AC.
22	67,495 S.F.	1,519.9 AC.
23	59,220 S.F.	1,359.5 AC.
24	57,119 S.F.	1,311.2 AC.
25	59,693 S.F.	1,370.3 AC.
26	57,826 S.F.	1,327.5 AC.
27	59,032 S.F.	1,351.1 AC.
28	59,254 S.F.	1,360.3 AC.



DATE

▲

▲

▲

ALLEN CONSULTING ENGINEERS, INC.
 2550 N. THUNDERBIRD CIRCLE #132
 MESA, ARIZONA 85215
 PHONE (480) 844-1666
 FAX (480) 830-8453
 E-MAIL: ace@allenconsultengr.com

ENCANTO PASEO FINAL PLAT

JOB NUMBER	93121	SHEET	2 OF 2
DRAWING	FINAL PLAT		
DRAFTSMAN	CHECKED BY	DATE	04-17-06

NOTE:

DRAINAGE EASEMENTS SHOWN ARE NOT THE LIMITS OF THE 100-YEAR FLOOD. DRAINAGE EASEMENTS INDICATE LIMITS OF 404 WASH & AREAS THAT MUST REMAIN UNDISTURBED. INDIVIDUAL GRADING & DRAINAGE PLANS MUST BE SUBMITTED FOR EACH LOT. FINISH FLOORS TO BE SET BY INDIVIDUAL LOT OWNER'S ENGINEER.

